

OUTLINE DRAWING

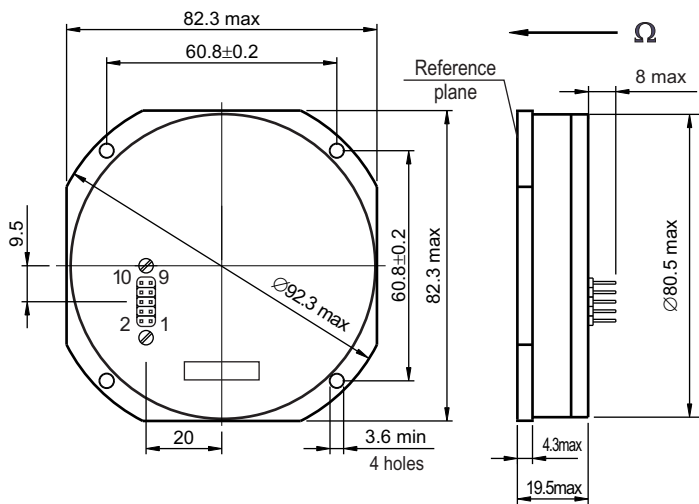

MAIN PARAMETERS (typical values)

- ◆ Rate range 150 deg/s
- ◆ Scale Factor (SF) 7 mV/deg/s
- ◆ Frequency range 0... 0.45 kHz
- ◆ Angle random walk 0.03 deg /√h
- ◆ Bias stability, RMS 2 deg / h
- ◆ SF stability, RMS 0.1 %
- ◆ Readiness time 0.1 s

ENVIRONMENT

- ◆ Temperature operating -40°C ... +70°C
- ◆ Temperature endurance -55°C... +85°C
- ◆ Vibration, RMS 12 g, 20Hz... 2000Hz
- ◆ Shocks 150 g, 1 ms
- ◆ Acceleration 5 g

◆◆ RELIABILITY

- ◆ MTBF 60000 hours (20°C, predicted)
- ◆ Lifetime (predicted) 15 years

- ◆ Precision class - ④
- ◆◆ Estimated for low humidity

CONNECTION DIAGRAM

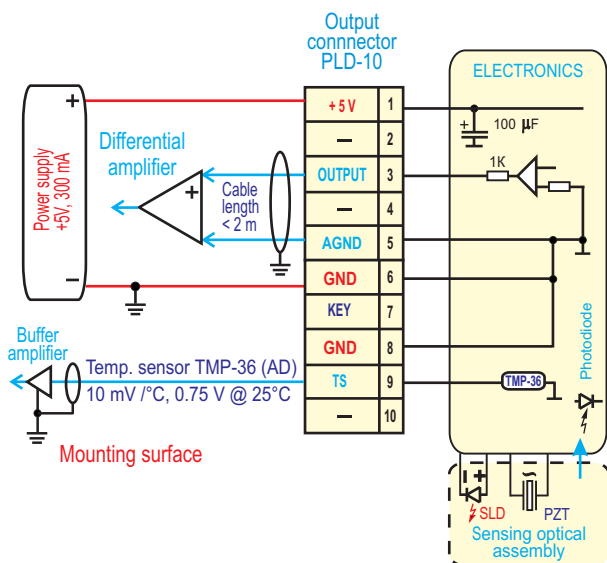

DESCRIPTION OF OUTPUT CONNECTOR PLD-10

Contact	Name	Comments
1	+ 5 V	Power input +5V ± 0.25V, 200mA max, ripple 10mV max within 0-1MHz
2, 4	-	Reserved
3	OUTPUT	Output voltage proportional to rotation, scale factor 7 mV/deg/sec. Differential input recommended.
5	AGND	Analog ground to use with "OUTPUT". Differential input recommended. Galvanic coupling with "GND".
6, 8	GND	Power return line, ground, "floating" contact to housing
7	KEY	Shortened pin
9	TS	Output of temperature sensor (TMP-36) 10mv per deg.C; 0.75V at 25 deg.C
10	-	Reserved

RECOMMENDATIONS AND PRECAUTIONS

1. Do not deform housing
2. Fragile components inside - no shocks, no drop
3. Treat as electrostatic sensitive unit
4. Is designed to be mounted inside water protected equipment
5. Increased humidity shortens essentially lifetime
6. Mounting surface must be grounded
7. Power must be off during connecting
8. Soldering to contacts - by low-temperature solder

PHYSICAL PARAMETERS

1. Ω - sensing axis, 90°± 0.5° to the reference plane
2. Dissipation - 1 W
3. Weight - 110 gram (150 gram max)
4. Volume - 0.1 litre
5. Housing material - aluminum alloy
6. Housing protection - powder coating
7. Tolerances per ISO 2768-m
8. Ingress protection class - IP67